

# **Lec**

## **USER GUIDE**

**U50262W**



## **Thank you for buying this high quality appliance**

This handbook is designed to help you through each step of owning your new appliance, from installation to use.

Please read through this handbook carefully before you start using your appliance, as we have endeavoured to answer as many questions as possible, and provide you with as much support as possible.

If, however, you find something missing or not covered, please contact our Customer Care Centre, using the number at the back of this handbook, who will be only too happy to help you.

Our policy is one of constant development and improvement, therefore we cannot guarantee the strict accuracy of all our illustrations and specifications, changes may have been made subsequent to publishing.

# Index

<b>BEFORE USING THE APPLIANCE .....</b>	<b>3</b>
Safety Instructions .....	3
Recommendations .....	4
Installation and Switching On The Appliance .....	5
Before Switching On .....	5
<b>THE VARIOUS FUNCTION AND POSSIBILITIES .....</b>	<b>6</b>
Thermostat Setting .....	6
<b>ARRANGING FOOD IN THE APPLIANCE .....</b>	<b>7</b>
<b>CLEANING AND MAINTENANCE .....</b>	<b>8</b>
Defrosting the Freezer compartment .....	9
<b>TRANSPORTATION AND CHANGING OF INSTALLATION POSITION .....</b>	<b>10</b>
<b>BEFORE CALLING YOUR AFTER SALES SERVICE .....</b>	<b>11</b>
Technical data .....	12
<b>THE PARTS OF THE APPLIANCE AND THE COMPARTMENT .....</b>	<b>13</b>
Changing of Door Opening Direction .....	14

## **PART- 1. BEFORE USING THE APPLIANCE**

### **Safety Instructions**

- The model, which contains R600a-see name plate under refrigerant (the coolant isobutane), natural gas that, is very environmentally friendly but also combustible. When transporting and installing the unit care must be taken to ensure that none of the refrigeration circuit components become damaged. In the event of damage avoid naked flames or ignition sources and ventilate the room in which the unit is placed for a few minutes.
- Warning: Keep ventilation openings in appliance enclosure or in structure for building in, clear of obstruction.
- Do not use mechanical devices or other artificial means to accelerate the defrosting process.
- Do not use electrical appliances in the freezer compartment of the appliance.
- If this appliance is to replace an old refrigerator with a lock; break or remove the lock as a safety measure before storing it, to protect children while playing might lock themselves inside.
- Old refrigerators and freezers contain insulation gases and refrigerant, which must be disposed of properly. Entrust the disposal of a scrap unit categorically to competence of your local waste disposal service and contact your local authority or your dealer if you have any questions. Please ensure that the pipe of work of your refrigerating unit does not get damaged prior to being picked-up by the relevant waste disposal service.

### **Important note:**

Please read this booklet before installing and switching on this appliance. The manufacturer assumes no responsibility for incorrect installation and usage as described in this booklet.

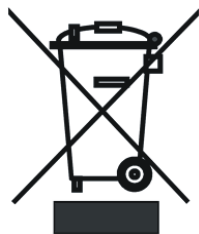

Please ask your municipal authority about the disposal of the WEEE for the reuse, recycle and recovery purposes.

## Recommendations

**Warning:** Do not use mechanical devices or other means to accelerate the defrosting process, other than those recommended by the manufacturer. Do not use electrical appliances inside the food storage compartments of the appliance, unless they are of the type recommended by the manufacturer. Keep ventilation openings, in the appliance enclosure or in the built-in structure, clear of obstruction. Do not damage the refrigerant circuit.

- Do not use adapters or shunts which could cause overheating or burning.
- Do not plug old, warped power supply cables.
- Do not twist and bend the cables.



- Do not allow children to play with the appliance. Children must NEVER sit on drawers/shelves or hang from the door.
- Do not use sharp metal objects for removing ice on the freezer compartment; they could puncture the refrigerator circuit and cause unreparable damage to the unit. Use the plastic scraper provided.
- Do not plug the power supply with wet hands.
- Do not place containers (glass bottles or tin containers) of liquids into the freezer especially gassy liquids as they could cause the container to burst during freezing.
- Bottles that contain a high percentage of alcohol must be sealed well and placed vertically in the freezer.
- Do not touch the cooling surfaces, especially with wet hands as you could be burnt or hurt.
- Do not eat ice, which have just been removed from the freezer.
- The appliance is not intended for use by people (including children) with reduced physical, sensory or mental capabilities, or lack of experience and knowledge, unless they have been given supervision or instruction concerning use of the appliance by a person responsible for their safety. Children should be supervised to ensure that they don't play with the appliance.
- If the supply cord is damaged it must be replaced by the manufacturer or service agent or similiary qualified people in order to avoid a hazard.

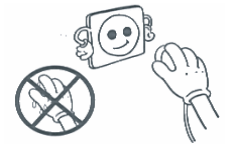

## Installation and Switching On The Appliance

- This appliance is connecting to 220-240V and 50 Hz.
- You can offer help from the service to install and switching on the appliance.
- Before making the connection to the power supply, ensure that the voltage on the name plate corresponds to the voltage of electrical system in your home.
- Insert the plug into a socket with an efficient ground connection. If the socket has no ground contact or the plug does not match, we suggest you to call an authorised electrician for assistance.
- The plug should be accessible after the appliance is positioned.
- Manufacturer is not responsible for failure to complete the ground connection as described in this booklet.
- Do not place the appliance in direct sunlight.
- Do not use in open air and shall not be exposed to the rain.
- Place the appliance far from heat sources and in a well-ventilated position. The freezer should be at least 50 cm from radiators, gas or coal stoves and 5 cm far from electrical stoves.
- Keep the top free for at least 15 cm.
- Do not place heavy and lots of things on the appliance.
- If the appliance is installed next to another freezer, observe a minimum distance of 2 cm to prevent condensation.
- Fit the plastic wall spacers to the condenser at the back of the refrigerator in order to prevent leaning to the wall for good performance.
- The appliance must be stand firmly and level on the floor Use the two front levelling-feet to compensate for an even floor.
- The outside of the appliance and the accessories inside should be cleaned with a solution of water and liquid soap; the inside of the appliance with sodium bicarbonate dissolved in lukewarm water. After drying replace all the accessories.

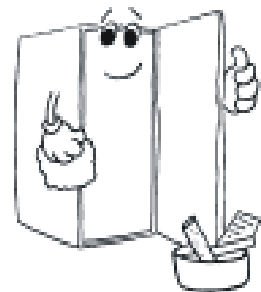

## Before Switching On

- Wait 3 hours before plugging the appliance in to the main power to ensure proper performance.
- There can be an odour when you first switch on the appliance. It will disappear after the appliance starts to cool.



## **PART- 2.** THE VARIOUS FUNCTION AND POSSIBILITIES

### **Thermostat Setting**

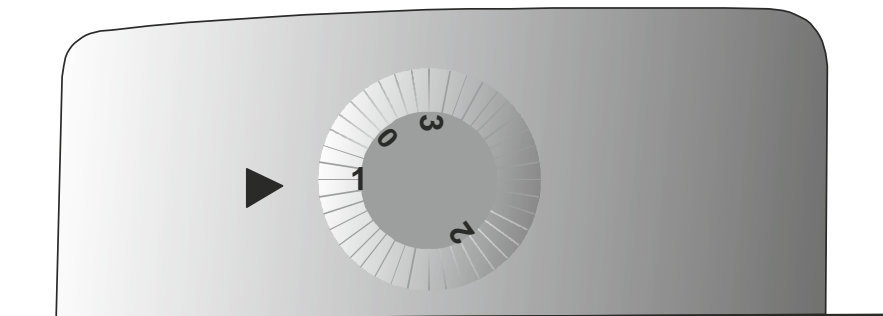

The freezer thermostat automatically regulates the inside temperature of the compartments. By rotating the knob from position 1 to 3, colder temperatures can be obtained. "0" position shows thermostat is closed and no cooling will be available.

#### **Freezer Thermostat Setting;**

0 : The appliance is closed

1 : For short-term storage of food in the freezer compartment, you can set the knob between minimum and medium position.

2 : For long-term storage of food in the freezer compartment, you can set knob to medium position.

3 : For freezing the fresh food. The appliance will work longer. So after you get the cold condition you must position to previous position.

**Note that;** *the ambient temperature, temperature of the freshly stored food and how often the door is opened, affects the temperature in the freezer compartment. If required, change the temperature setting.*



### **If your fridge is not cooling enough;**

Your fridge is designed to operate in the ambient temperature intervals stated in the standards, according to the climate class stated in the information label. We do not recommend operating your fridge out of stated temperatures value limits in terms of cooling effectiveness.

<b>Climate Class</b>	<b>Ambient Temperature (°C)</b>
<b>T</b>	Between 16 and 43 (°C)
<b>ST</b>	Between 16 and 38 (°C)
<b>N</b>	Between 16 and 32 (°C)
<b>SN</b>	Between 10 and 32 (°C)

- Tropical Climate Class is described as between 16°C and 43°C of ambient temperatures according to EN ISO15502 standards.
- Appliance complies with EN15502, IEC60335-1 / IEC60335-2-24, 2004/108/EC standards.

## **PART- 3. ARRANGING FOOD IN THE APPLIANCE**

- The use of freezer is, storing of deep-frozen or frozen food for long periods of time and making ice cubes.
- Do not put fresh and warm food with frozen food side by side as it can thaw the frozen food.
- While freezing fresh food (i.e. meat, fish and mincemeat) divide them in parts you will use in one time.
- For storing the frozen food; the instructions shown on frozen food packages should always be followed carefully and if no information is provided food should not be stored for more than 3 months from the purchased date.
- When buying frozen food ensure that these have been frozen at suitable temperatures and that the packing is intact.
- Frozen food should be transported in appropriate containers to maintain the quality of the food and should be returned to the freezing surfaces of the unit in the shortest possible time.
- If a package of frozen food shows the sign of humidity and abnormal swelling it is probable that it has been previously stored at an unsuitable temperature and that the contents have deteriorated.
- The storage life of frozen food depends on the room temperature, thermostat setting, how often the door is opened, the type of food and the length of time required to transport the product from the shop to your home. Always follow the instructions printed on the package and never exceed the maximum storage life indicated.
- Use the fast freezing shelf to freeze home cooking (and the food which is wanted to freeze) more quickly because of the freezing room's greater freezing power. Fast freezing shelves are the middle drawers of the freezer compartment (see in page 10).

- **While freezing food** ; Maximum amount of fresh food (in kg) that can be frozen in 24 hours is indicated on the appliance label.
- For optimum appliance performance to reach maximum freezing capacity , turn the thermostat knob to position max 24 hours before placing fresh food in the freezer.
- After placing fresh food in the freezer ,24 hours on max position is generally sufficient,After 24 hours, don not need to set the thermostat knob to position max.

**Attention;** In order to save energy, When freezing small amounts of food, don not need to set the thermostat knob to position max.

## **PART- 4. CLEANING AND MAINTENANCE**

- Disconnect unit from the power supply before cleaning.

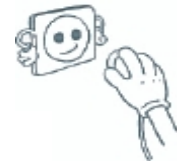

- Do not clean the appliance by pouring water.



- The freezer compartment should be cleaned periodically using a solution of bicarbonate of soda and lukewarm water

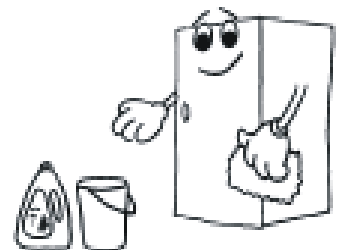

- Clean the accessories separately with soap and water. Do not clean them in the washing machine.

- Do not use abrasive products, detergents or soaps. After washing, rinse with clean water and dry carefully. When the cleaning operations have been completed reconnect the plug of the unit with dry hands.

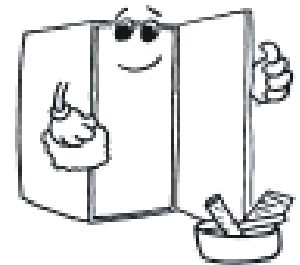

- You should clean the condenser (back of the appliance) with broom once a year in order to provide energy saving and increase the productivity.

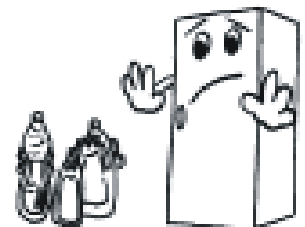

**THE POWER SUPPLY MUST BE DISCONNECTED.**

## Defrosting the Freezer compartment

### Freezer defrost process

- Small amounts of frost will accumulate inside the freezer depending upon the length of time during which the door is left open or the amount of moisture introduced. It is essential to ensure that no frost or ice is allowed to form at places where it will affect the close fitting of the door seal. This might allow air to penetrate the cabinet, thus encouraging continuous running of the compressor. Thin frost formation is quite soft and can be removed with a brush or plastic scraper. Do not use metal or sharp scrapers, mechanical devices or other means to accelerate the defrosting process. Remove all dislodged frost from the cabinet floor. For the removal of thin frost it is not necessary to switch off the appliance.
- For the removal of heavy ice deposits disconnect the appliance from the mains supply and empty the contents into cardboard boxes and wrap in thick blankets or layers of paper to keep them cold. Defrosting will be most effective if carried out when the freezer is nearly empty, and it should be carried out as quickly as possible to prevent undue increase in temperature of the contents.
- Do not use metal or sharp scrapers, mechanical devices or other means to accelerate the defrosting process. An increase in temperature of frozen food packages during defrosting will shorten the storage life. Provided that the contents are well wrapped and placed in a cool area they should keep for several hours.

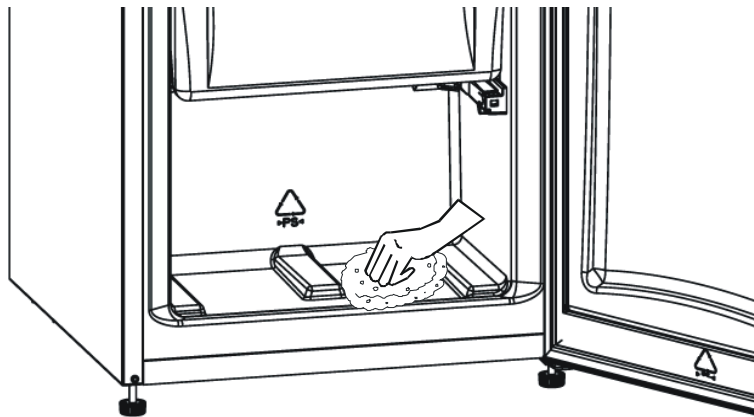

- Dry the inside of the compartment with a sponge or a clean cloth.
- To accelerate the defrosting process place one or more basins of warm water in the freezer compartment.
- Examine the contents when replacing them in the freezer and if some of the packages have thawed out it should be eaten within 24 hours or be cooked and re-frozen.
- After defrosting has finished clean the inside with a solution of warm water with a little bicarbonate of soda and then dry thoroughly. Wash all removable parts in the same way and reassemble. Reconnect the appliance to the mains supply and leave for 2 to 3 hours on setting number 5 before introducing the food back into the freezer.

## **PART- 5.**

# **TRANSPORTATION AND CHANGING OF INSTALLATION POSITION**

### **Transportation and Changing of Installation Position**

- The original packages and foamed polystyrene (PS) can be concealed if required.
- In transportation the appliance should be tied with a wide stripe or a strong rope. The rules written on the corrugated box must be applied while transporting.
- Before transporting or changing old installation position, all the moving objects (ie,shelves,crisper...) should be taken out or fixed with bands in order to prevent the shake.

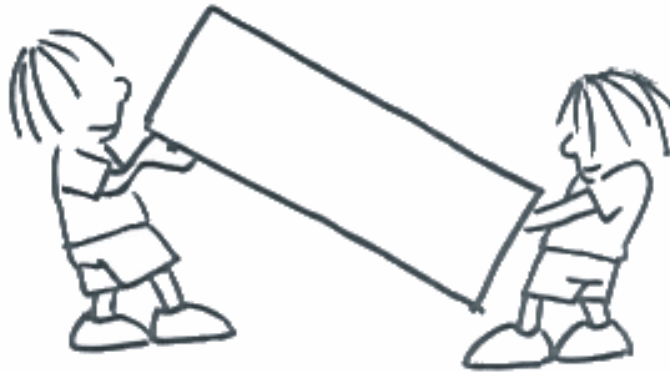

## **PART- 6.**

# **BEFORE CALLING YOUR AFTER SALES SERVICE**

If your appliance is not working properly, it may be a minor problem, therefore check the following, before calling an electrician to save time and money.

### **What to do if your appliance does not operate;**

#### **Check that;**

- There is no power,
- The general switch in your home is disconnected ,
- The thermostat setting is on« 0 »position ,
- The socket is not sufficient. To check this, plug in another appliance that you know which is working into the same socket.

## **What to do if your appliance performs poorly;**

### **Check that;**

- You have not overloaded the appliance ,
- The refrigerator and freezer thermostat settings is “1” position(if so set the thermostat dial suitable value)
- The doors are closed perfectly ,
- There is no dust on the condenser ,
- There is enough place at the rear and side walls.

### **If there is noise;**

The cooling gas which circulates in the cooling circuit may make a slight noise (bubbling sound) even when the compressor is not running. Do not worry this is quite normal. If these sounds are different check that;

- The appliance is well levelled
- Nothing is touching the rear.
- The stuffs on the appliance are vibrating.

### **Recommendations**

- If the appliance is not used for long time (for example during the summer holidays) unplug and clean the appliance and leave the door open to prevent the formation of mildew and smell.
- To stop the appliance completely, unplug from main socket (for cleaning and when the doors are left open)

## Technical data

Supplier's name or trade mark	<b>Lec</b>
Model / Item	U50262W
Type of appliance	GT/N1151K
The energy efficiency class	A+
Voltage	220-240V / 50HZ
Power	91.2 W
Energy consumption	0.483 kw / 24h
Net storage volume of frozen food	62 lt
Star rating of frozen food storage compartment	****
Refrigeration system	Static
Power cut safe Z h' (-18°C to -9°C)	510 mins
Freezing capacity'	9 kg
Climate class'	T/N
Size (W x D x H) mm	480 x 560 x 838
Net weight	30.47
Noise'	39 dB (A)

**PART-7.**

**THE PARTS OF THE APPLIANCE AND THE COMPARTMENT**

**U50262W**

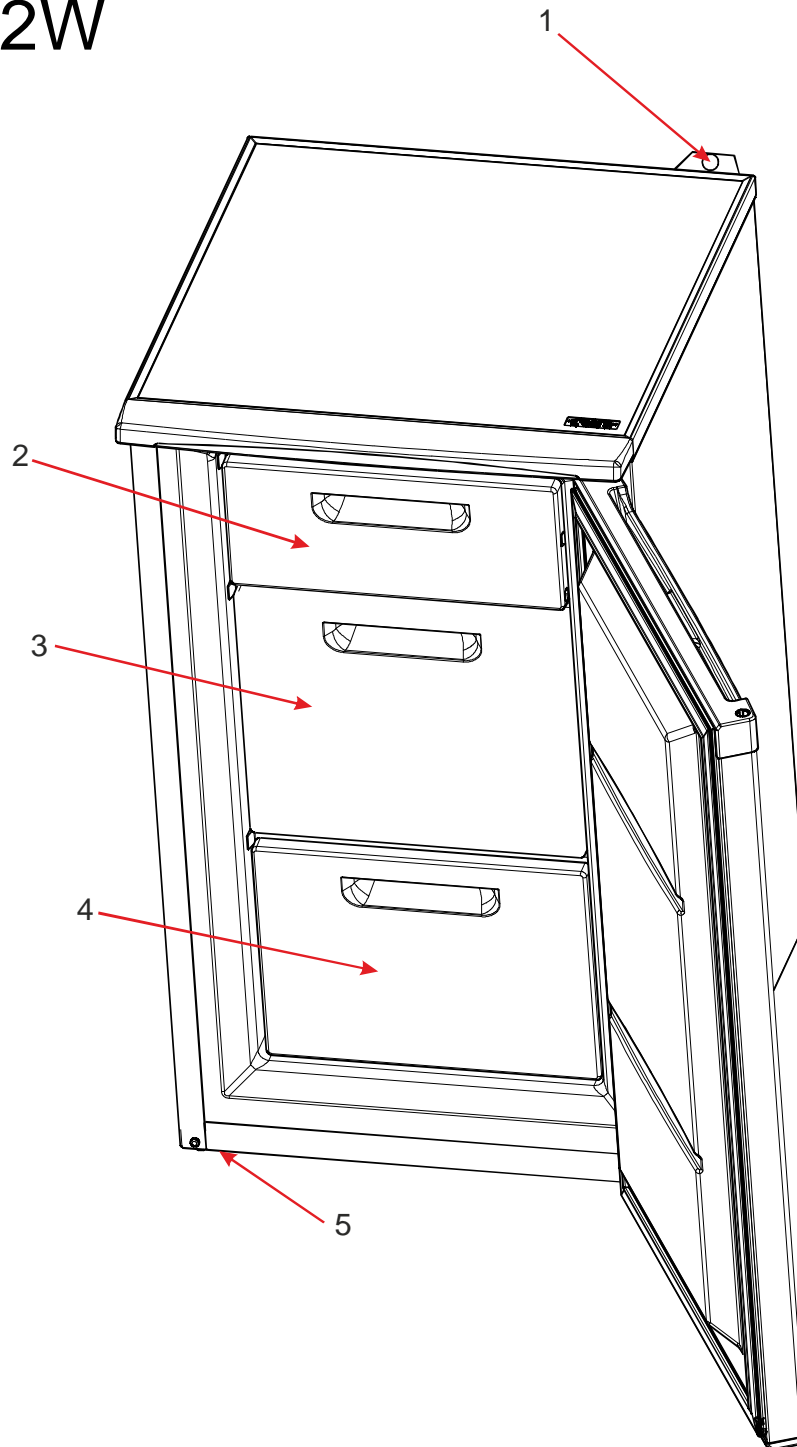

This presentation is only for information about the parts of the appliance.  
Parts may vary according to the appliance model.

1) THERMOSTAT DIAL

2) FREEZER ROOM COVER

3) FAST FREEZER COMP. DRAWER

4) FREEZER COMP. BOTTOM DRAWER

5) LEVELING FOOT

## Changing of Door Opening Direction

**Step-1:** Lie down the appliance to the left side. (FIG-1)

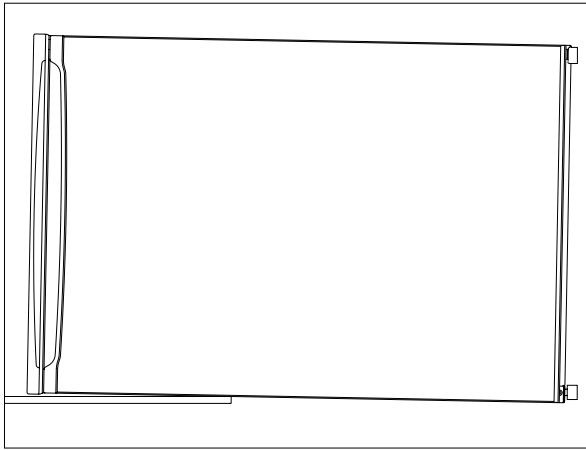

Fig. 1

**Step-2:** Dismantle both leveling foot. (FIG-2)

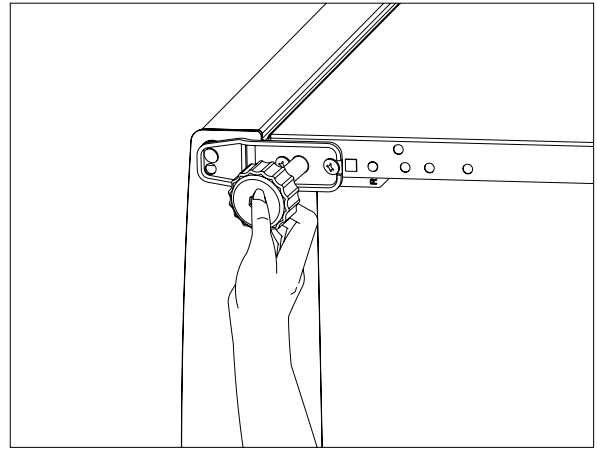

Fig. 2

**Step-3:** Unscrew the bottom hinge fixing screws and remove it. (FIG-3.1)

Unscrew the bottom hinge pin and screw in the next hole. (FIG-3.2)

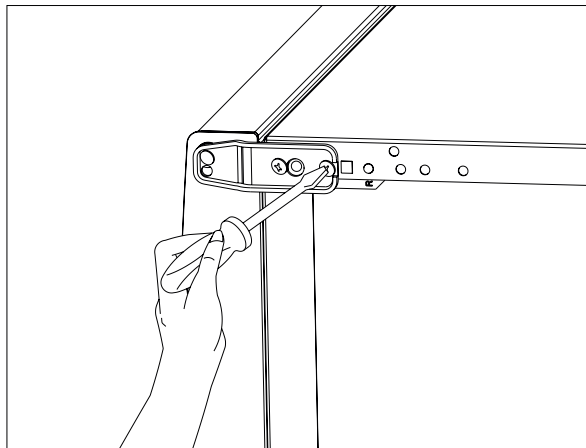

Fig. 3.1

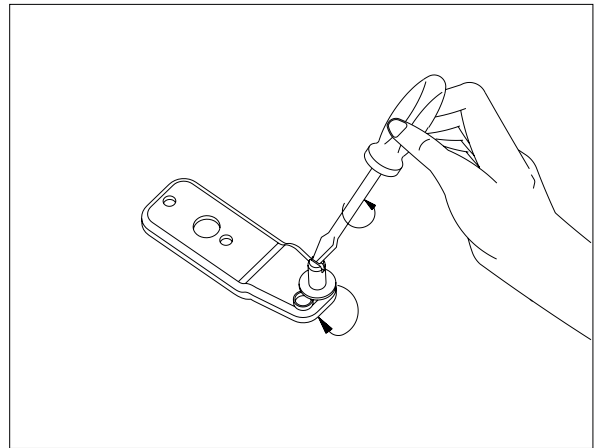

Fig. 3.2

**Step-4:** Remove the door. (FIG-4)

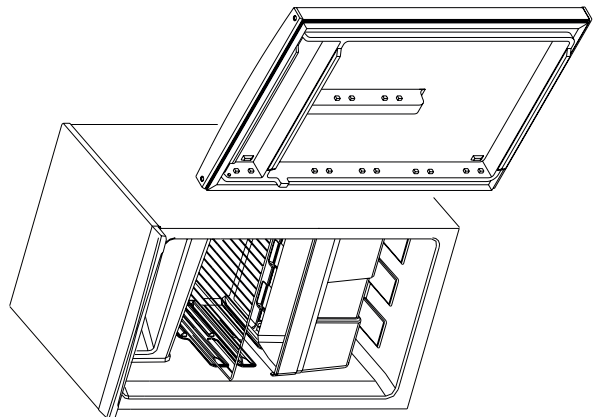

Fig. 4



**Step-5:** Unscrew the right pin of the top hinge (FIG-5.1)

Screw the pin on the left hole of the top hinge (FIG-5.2)

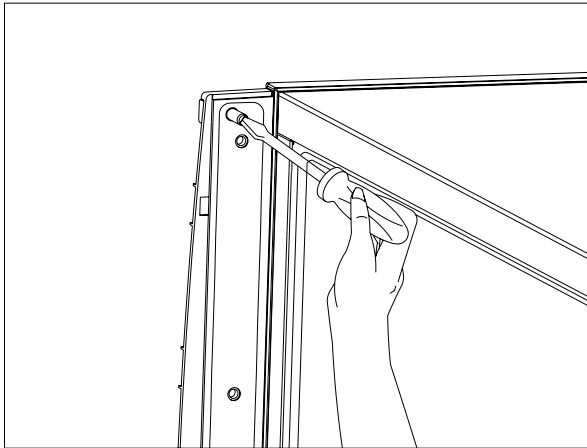

Fig. 5.1

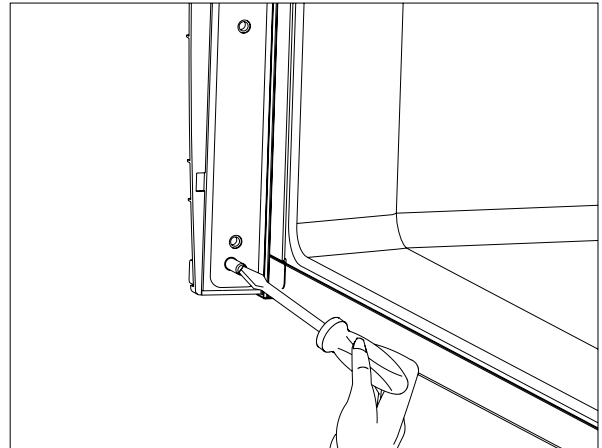

Fig. 5.2

**Step-6:** Replace the top bushing and top bushing cap. (FIG-6)

(You can use the bushing cap that is put in the user manual bag)

Remove the bottom bushing and assemble it to the left side. (FIG-6)

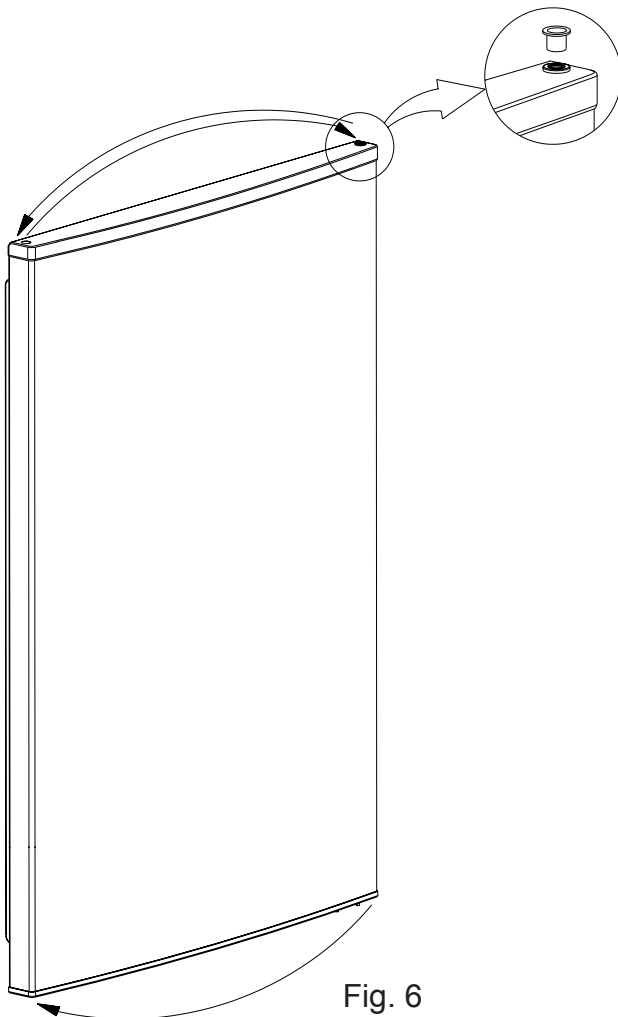

Fig. 6

## LEC CUSTOMER CARE

Please keep this handbook in a safe place.

Please fill in the model number and serial number in the spaces provided below as they will assist us should you need to call.

**0844 815 3737**

When you dial this number you will hear a recorded message and be given a number of options. This indicates that your call has been accepted and is being held in a queue. Calls are answered in strict rotation as our Customer Care Representatives become available.

Enter appliance numbers here for future reference:

Model No

--	--	--	--	--	--	--	--	--	--

Serial No

--	--	--	--	--	--	--	--	--	--

These numbers can be found on your appliances.  
Outside the UK and Northern Ireland, refer to your local supplier.

# **Lec**

Stoney Lane, Prescot, Merseyside, L35 2XW

# ELECTRICAL CONNECTION (UK ONLY)

For your safety please read the following information

**Warning: This appliance must be earthed.**

This appliance operates from 220-240 volts and should be protected by a 13 amp fuse in the plug.

The appliance is supplied with a standard 13 amp 3-pin mains plug fitted with a 13-amp fuse. Should the fuse require replacement, it must be replaced with a fuse rated at 13 amp and approved to BS1362.

If the mains plug which is fitted is unsuitable for the socket outlet in your home or is removed for any other reason, please follow the instructions below on how to wire a 13 amp 3 pin plug..

## How to wire a 13 amp plug.

Important

The wires in the mains lead on this appliance are coloured in accordance with the following code:

Green and Yellow - Earth

Blue – Neutral

Brown – Live

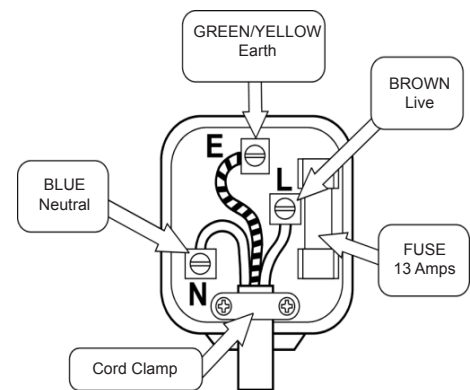

As the colours may not correspond with the markings identifying the terminals in your plug proceed as follows.

The green and yellow wire must be connected to the terminal in the plug which is marked with the letter E or with the earth symbol  $\equiv$  or coloured green and yellow.

The blue wire must be connected to the terminal marked N.

The brown wire must be connected to the terminal marked L.

You must make sure the lead is firmly secured under the cord clamp.

